



WARP KNITTING  
经编机

## RDJ 6/2 EN

### RDJ 6/2 EN Double Needle Bar Machines for high-quality production for all sorts of Jacquard spacer fabrics

RDJ 6/2 EN双针床经编机, 生产各类高品质贾卡间隔面料

#### Your benefit

- Enhance customer's design possibilities:
  - One additional Jacquard bar (4 GB and 2 JB)
  - EN drive for highly efficient production speed combined with easy and flexible patterning
  - Two Jacquard bars can realize two-colour Jacquard pattern effect for free pattern design and colourful pattern variations
- Placement of holes for breathability or additional design effects
- Wide range of product applications

#### 您的优势

- 增强设计可能性:
  - 更多的贾卡梳 (4把GB和2把JB)
  - EN提花机构, 保证高效的生产速度、简便的操作和灵活的提花能力
  - 2把贾卡梳可实现双色的提花效果, 花型设计更加自由, 花型变化更加丰富、多彩
- 网孔用于透气或产生额外的设计效果
- 产品应用广泛

# RDJ 6/2 EN

## Technical data

### 技术参数

#### Working width / Gauge

3505 mm = 138"  
E 22, E 24

#### Knock-over comb bar distance

1–5 mm, continuously adjustable, incl. patented stitch comb swivelling device

Option: central trick plate distance readjustment

#### Bars / Knitting elements

Two needle bars with latch needle units, two knock-over comb bars, two stitch comb bars, four ground guide bars, two Piezo Jacquard bars (split execution)

Option: individual needle bars

#### Warp beam support

6 × 812 mm = 32"  
(free-standing)

Option: 8 × 812 mm = 32"

#### KAMCOS® (KARL MAYER COMMAND SYSTEM)

Operator interface to configure, control and adjust the electronic functionality of the machine

#### Fabric take-up

Four-roller system, driven by an electronic drive

#### Batching device

No. 14-J1

#### Pattern drive

EN-drive with eight electronic guide bar drives  
Max. shog distance:  
ground 18 mm, Jacquard 10 mm

#### Electrical equipment

Speed-regulated main drive, power-failure safe with separate fine-positioning function, total connected load 25 kVA

#### 工作门幅/机号

3505 mm = 138英寸  
E 22, E 24

#### 脱圈板间距

1–5 mm, 无极调节, 配有受专利保护的沉降片床释放装置

选配: 脱圈板中央隔距调节装置

#### 床体/成圈机件

2个装有舌针针块的针床, 2个脱圈板床以及2个运动的沉降片床。4把地梳, 2把贾卡梳(分离式)

选配: 嵌入式针床

#### 经轴架

6 × 812 mm = 32英寸  
(独立式)

选配: 8 × 812 mm = 32英寸

#### 卡迈酷斯® (卡尔迈耶控制系统)

操作界面, 用于设置、控制和调节机器的电控部分功能

#### 织物牵拉机构

4罗拉系统, 由电机传动

#### 卷取机构

14-J1 号卷取机构

#### 提花机构

配备8个横移电机的EN提花机构  
最大横移距离:

地梳18 mm, 贾卡梳10 mm

#### 电子设备

调速主电机, 断电保护, 具有独立的精确定位功能, 机器总连接负载25千伏安

#### End uses

Spacer, shoe fabric, outerwear, medical, semi-technical application, mattresses

#### 终端用途

间隔织物, 鞋材, 外衣, 医疗, 半技术应用, 床垫



RDJ 6/2 EN knitting elements  
RDJ 6/2 EN成圈机件

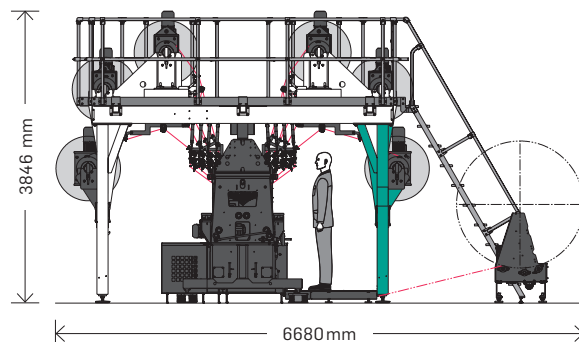

Total width 宽度  
6470 mm  
Total depth 纵深  
6680 mm  
Total height 高度  
3846 mm